



**INTERNATIONAL JOURNAL OF ENGINEERING SCIENCES & RESEARCH
TECHNOLOGY**

**Developing a GUI based Design Software in VB Environment to Integrate with
CREO for Design and Modeling using Case Study of Coupling**

Indrajitsinh J. Jadeja^{*1}, Kirankumar M. Bhuptani²

^{*1} Department of Mechanical Engineering, Atmiya Institute of technology and science, Rajkot
Gujarat, India

² Principal, Department of Mechanical Engineering, Atmiya Institute of technology and science
for diploma study, Rajkot Gujarat, India

indrajit.jadeja@gmail.com

Abstract

The Research Work is carried out on the approach of a CADD (Computer Aided Design and Drafting) and Concurrent engineering. Because with the use of this developed system all phase of product development Design, modeling and analysis is work on a bench. The work reviews the procedural steps involved in the design of couplings and the development of the software package using visual basic as a tool for the design. This system is carried out on the case study of flange coupling and standard design equation being carried out together with the use of programming software and use CREO as modeling software after getting output from the designing software.

Keywords: Automated design and modeling, CADD, Excel Analysis, GUI, Parametric Approach.

Introduction

In a Recent scenario of Research and development wing of any industry are to be working on a atomization of Design and drafting with ease. Because we know that when we increasing the productivity of Design and modeling phase in the product design development, we save much time and it will be further utilize for a next Phases of product design and development. There are number of software is available for drafting and modeling as well as for analysis like AutoCad, Pro-engineering, Solid works, Ansys etc. But not specific software is available for Design a Product. So By this Dissertation approach we will made a one tailor-made software which are useful for designing a specific component and output of the software is easily being integrating with other software of Modelling and analysis which said above.

For the develop a tailor-made software we required a programming language which are to be useful in making of a calculation of designing said input parameter. In the computer science there are number of computer language available like C, C++, Java, Visual Basis etc..

Stage-I had been selecting a programming language is C++ for designing purpose, but there are

Problem regarding the interfacing with other database with the use of above said language so, we will be switch over to another Programming Language

VB (Visual Basic). It will give us better frame work for a designing input base as well as easily interface with intermediate software like Excel, access, notepad which are to be providing a input to a other Modelling or analysis software as said above.

After selecting languages which are to be useful for developing design software, the next stage is to selecting a mechanical component for case study for run the software and get output. For this first we had been selecting a component coupling which are has a assembly of three different components Key, Shaft, coupling and also some standard fastening component bolt and nut. As we know that coupling is used for transmitting a power and as well as joining and support the shaft structure. Another reason behind the selection of coupling is that a Rajkot industry as well as nearer to Rajkot industries are hub of automobile industries and coupling is a integral part of automobile. so this software can easily utilize by a industries.

There are different type of coupling is available in market on the basis of it's application solid coupling, sleeve coupling, split-muff coupling, flange coupling etc. Among them we had been selected a coupling type Unprotected type flange coupling for a case study approach. Before the actual work being started, we had been review the different research paper which are

to be published on the study of automated designing and drafting approach with differential mechanical component.

Methodology

The following mention flow chart shows the how the tailor-made software will be developed each step being easily mention in the figure.

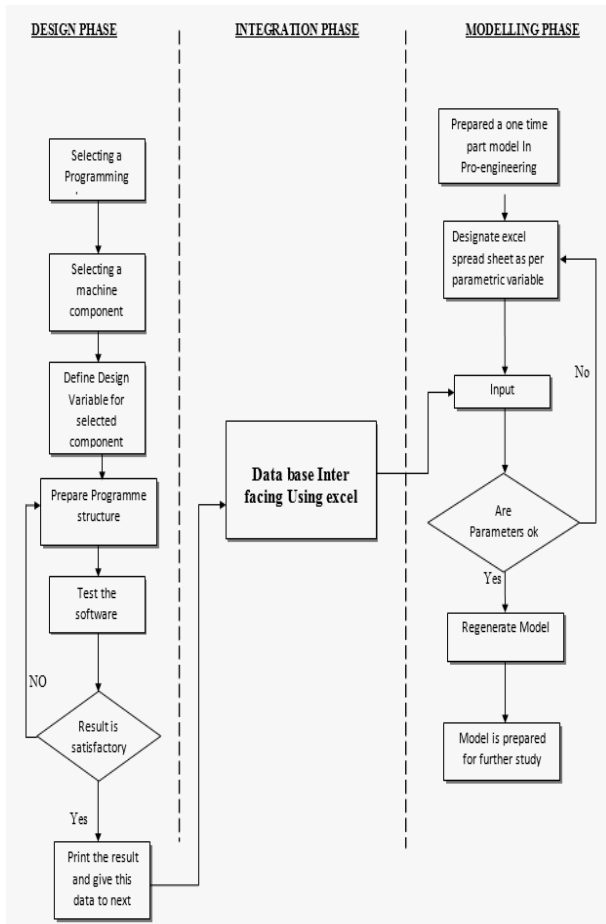

Fig 2.1 methodology

We had been prepared for a developing a designing software for a case study of coupling and designating language is selection as a Visual basic 6.0 , for integrating of data with Modelling software I used a intermediate software is Microsoft excel and for Modelling , analysis purpose selecting a pro-engineering wildfire software. After selection process is being complete selecting a methodology for carried out dissertation work step by step. Stage of methodology is as given below.

Design Phase

- Selecting a Programming Language
- Selecting a Machine Component

[http:// www.ijesrt.com](http://www.ijesrt.com)(C)International Journal of Engineering Sciences & Research Technology

- Design Variable and Equation
- Programming Structure and Frame Work

Integration Phase

Modelling Phase

- Prepared a solid model of all component
- Assembled all component
- Integrated with 2nd Phase

Design Phase

In this stage of the interfacing system selection of the mechanical component and programming language being done. For selecting a programming language, required of fulfillment of two criteria first is software based on a GUI (Graphics User Interface) and second requirement is, database integration with tailor made software. There are many programming language available in computer science which fulfillment the above two criteria like Visual Basic, C++, Java etc. among the we have been selecting a VB because in VB there a library function of excel as well as access which are used for integration purpose with the database which are to be prepared in excel or in a access. we had been selecting a Coupling for a software preparation because the coupling to be standardized as well as coupling has a four integral part viz. shaft, key, coupling, bolt and Nut. There are a wide variety of couplings available in the market like Sleeve and muff coupling, Protected type flange coupling, Bush type coupling and universal coupling. Among them protected type flange coupling being selected for case study. figure of flange coupling is as shown below with part list.

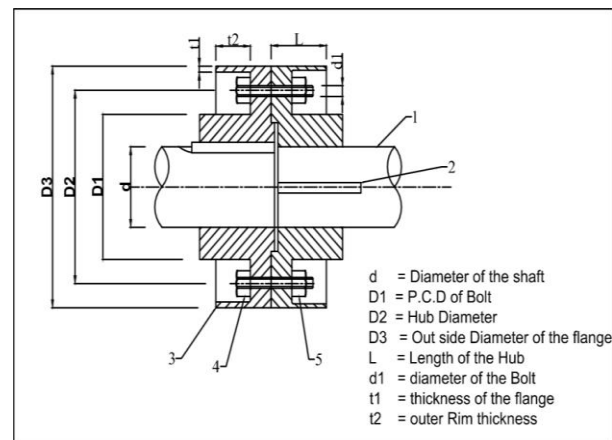

Fig 3.1 Protected type flange coupling

After successfully selection of mechanical component for designing next stage is to be collected data regarding to which parameter is being used as input and which is as output according to the

application of the component. As we selecting a component Flange Coupling on the basis of the application of its input power. Selecting a input variable as a Power, rpm of the shaft & shear stress for hub material, bolt material and Key. For the output variable I had been selecting a shaft diameter, key size (width & depth), number of bolt required for flange coupling, P.C.D of the bolt, Hub diameter, Outside diameter of the coupling, bolt diameter, Hub length, flange thickness and mean radius.

List of the Input variable and output variable against its notation which are to be as given below

Input Variable:-

Power (Kw) = P

Revolution (rpm) = N

Shear Stress for Hub (Mpa) = τ_1

Shear Stress for Bolt (Mpa) = τ_2

Shear Stress for Key (Mpa) = τ_3

Output Variable with design equations:-

Torque (T) = $(P * 60 * 1000) / (2 * \pi * N) * S_f$

Shaft Dia. (d) = $\{(16 * T * 1000) / (2 * \pi * \tau_1)\}^{0.3333}$

Number of Bolt required n = $0.02d + 3$

P.C.D. of the flange (D₁) = 2d

Hub diameter (D₂) = 1.5d

Outside diameter (D₃) = 3d

Bolt diameter (d₁) = $\{(8 * T) / (\pi * \tau_1 * D_3)\}^{0.5}$

Hub length (L) = 1.25d

Mean Radius (r_m) = $(D_3 + d) / 2$

Flange thickness (t) = 0.25d

In the 3rd stage of the system is the prepared a frame work and programming structure for the design phase. for this task we used a Visual Basic as a programming language, Because Visual basic programming language is user interface language and easily being integrated with other software. Typical view of the software which are as given below.

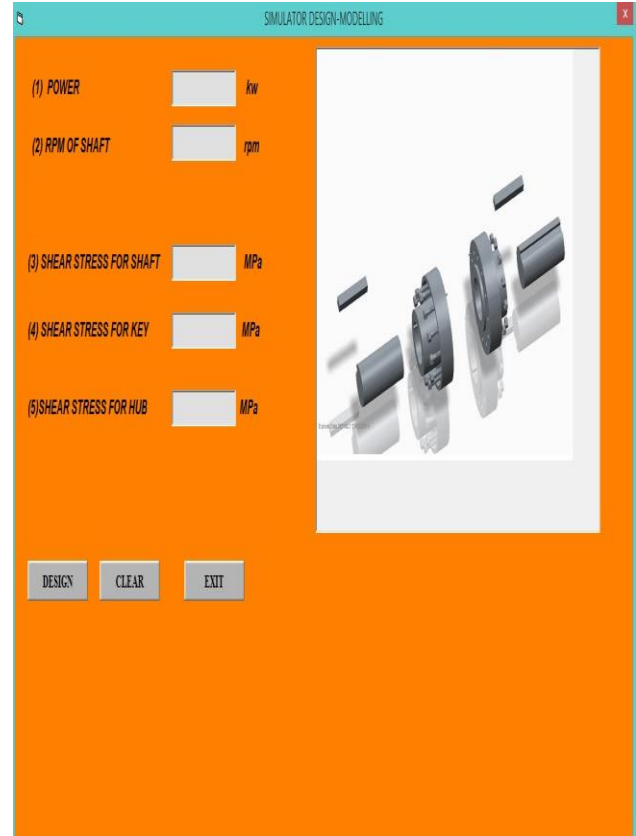

Fig 3.2 Design Module

Integration Phase

We are shown in the above design phase still output of the design module in the form of a VB data so that we required a tool which can give the output data in the form of a printable file so that we can easily used that data for further study. For purpose of the output file we are selecting tools Microsoft excel because it can be easily generated databases and also connected with a any Modelling software.

Protected type flange coupling is standard component. So for selecting a standard value required to prepare a database related to the variable. In protect type flange coupling all the variable (which are to be mention above) are get to be standardized on the basis of Diameter of the shaft. For preparation of the database we required a referred a standard, so the referred a IS standard related to a flange coupling .Selected a three standard database Coupling Database, Key Databases and nut and bolt database. Lastly afterward prepared a design output sheet in Microsoft excels which are as given below.

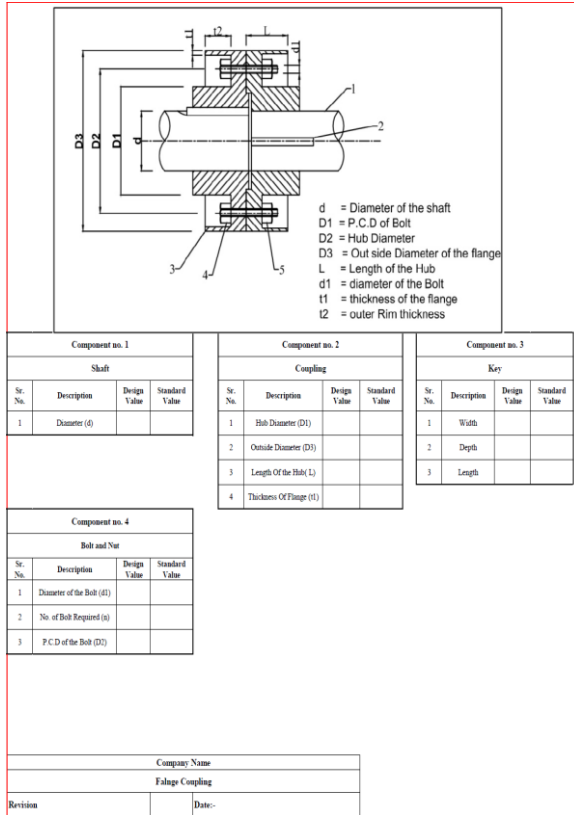

Fig 4.1 Design Output

As seen the above figure there are all variable of each component showing the two value one is the design value which is to be getting from a design phase related to a stress analysis and second one is the standardized value related to a shaft diameter value.

Modelling Phase

It is the final stage of the developed system is preparing a 3-dimensional solid model of the protective type flange coupling. as we know that now a days there are a wide variety of Modelling software available in the market. So for the selection of the Modelling software is very much difficult task. each Modelling software has it's own special feature so for our study we have to be selected a software which has a parametric feature because the dimension of the output stage of design phase as well as integrated phase is variable in nature. We had been selected a parametric software CREO which is parametric and nature as well as it could be integrated with the excel database. This phase completing in the following manner.

For integration purpose we are required a first model of all components because for compare Modelling variable with design parameter so that the model can generated as per design. Protected type

flange coupling has a following SIX component to require a modeling.

1. SHAFT
2. FLANGE COUPLING (MALE)
3. FLANGE COUPLING (FEMALE)
4. BOLT
5. NUT
6. RECTANGULAR SUNK KEY

Final assembly of six component is as shown given below.

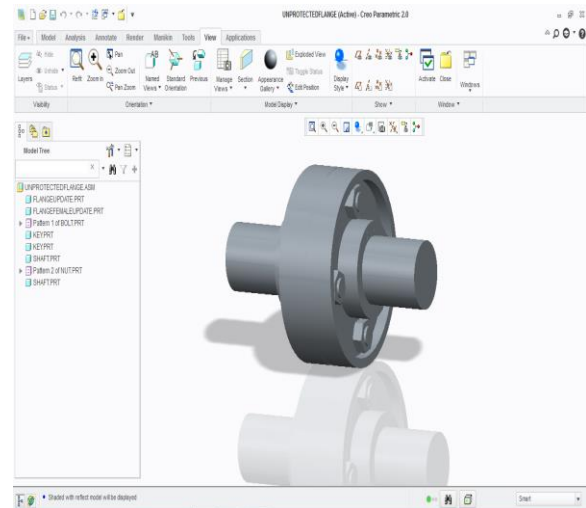

Fig 5.1 Assembly in CREO

Now in the Final stage of the tailor made system. In this stage each model viz. shaft, coupling, key, bolt and nut are to be integrated separately. The whole procedure of the linkup is shown step by step in below figures.

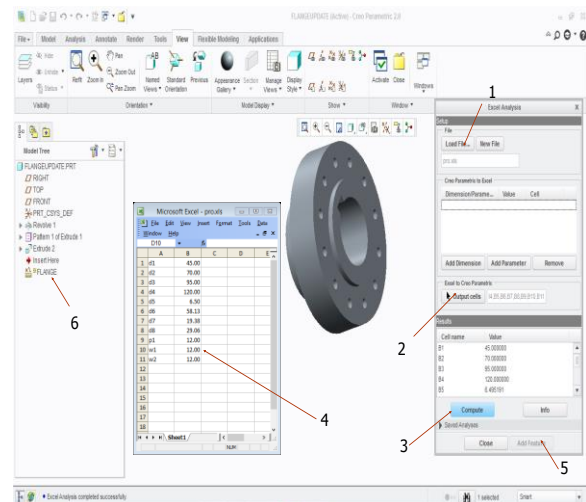

Fig 5.2 Integration of CREO with Excel

Step 1:- using Excel analysis feature in Creo Load the excel file which contain the all parameter related to a integrated phase output

Step 2:- Select the all cell related to a Modelling parameter.

Step 3:- Compute the selected value as so the all nomenclatures related to model dimensions

Step 4:- Updated the excel sheet using output file of 2nd phase against nomenclature.

Step 5:- Finally add the feature using Add feature button

Step 6:- Now Feature is to be shown in the Model tree.

Step 7:- The Above mention procedure is repeated to the all solid model .part file for integration purpose.

After the integration is completed just regenerated model and updated the dimensions as per 2nd phase output.

Case Study

Design and modeling a Couple to Transmitted a power 30 KW at 300 rpm. Take shear stress for shaft material is 40 N/mm² for Key 60 N/mm² & for Hub 8 N/mm².

(i) Step I

Start simulator Design-Modelling software and enter the all variable given in the problem. The typical figure is shown as given below



Fig 6.1 Input parameters in design module

(ii) Step II

After applying the all value click on the Design button to get output this is to be shown in the fig

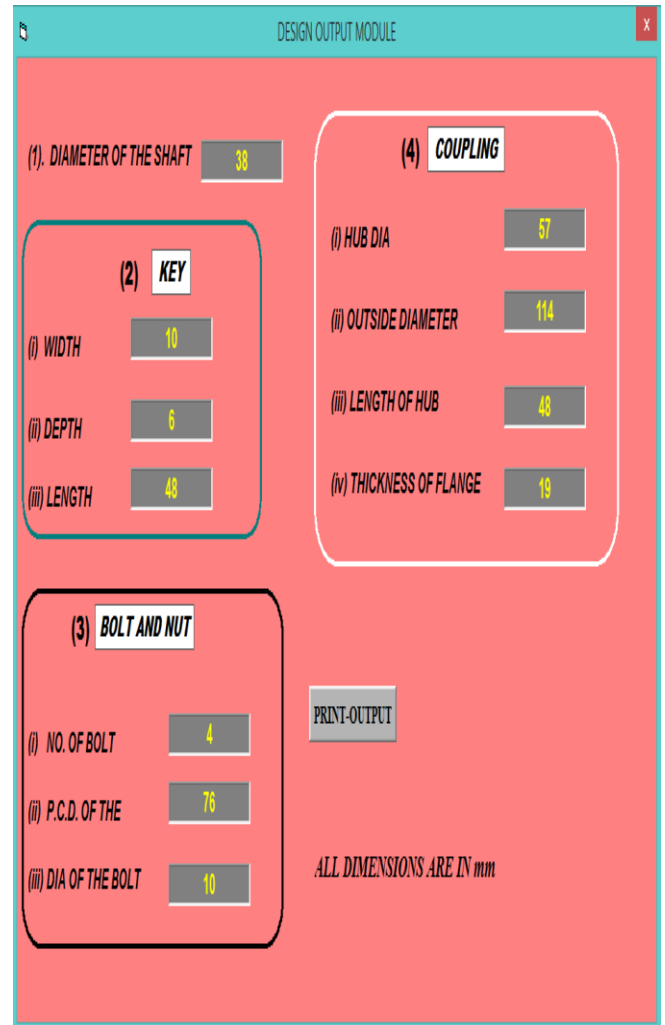

Fig 6.2 output parameter in Design output module

(iii) Step III

Now next step is to be transfer the all value to a excel for link up. For this task press on the “Print-Output” button. After clicking you get the output file in the excel format with both design value as well as standard value. Fig 6.3 shows the step III operation.

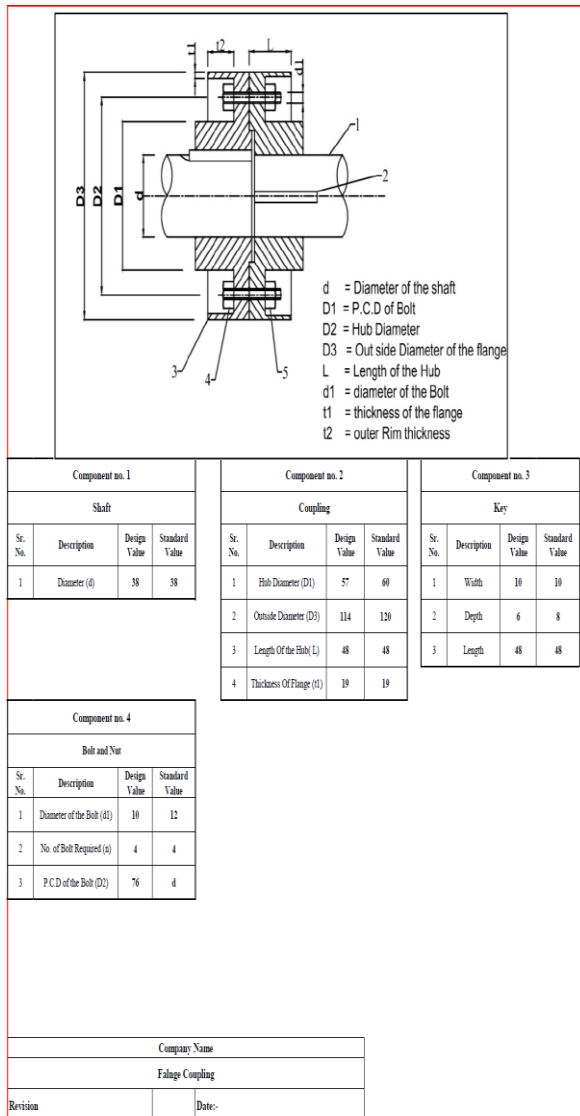

Fig 6.3 Excel Integration with standard database

(iv) Step IV

Now next step is to be open the all model viz. shaft, key, coupling male & female, bolt and nut in Modelling software. After open the model just edit the feature which are to be related to integrated phase file regenerated the model you see the all dimensions of the model is changed. For that study here we give a just one component example in the figure 6.4.

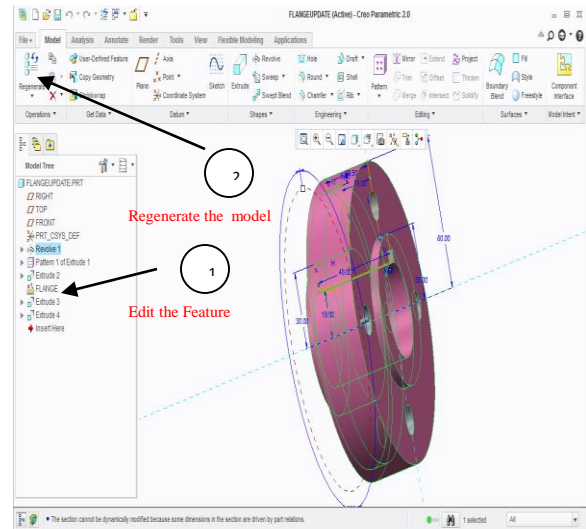

Fig 6.4 Regenerate the Model

Step IV is repeated for the entire model till the entire model is regenerated. After that just open the assembly file it will also automatically regenerated.

Scope of the Work

- As we know that there are number of research is being done on the shaft coupling for the design with theoretical approach and the all result is put together for the user of the engineer and also one software is also made for the coupling is coupling cad on the platform of java but is research had been limited to design phase only. But the approach of this dissertation system I elaborated its work to a 3d-parametric modeling and also a structure analysis. So the development of the component is being easily concluded and gives better result for the said component.
- This system provides a KBS (Knowledge base System) to a industries. Because as we know that persons who are working the industries as own limitation so If the person leave the industries the work can being easily adopted by any newly person appointed.
- Company which would not use any kind of modeling software this system would be play the key role in the development of the above said component.
- As design and modeling consume the more time in the development of the component, so with the use of this system with ease save much more time of the industries so that time will be used for reaming stage of the development.

References

- [1] Adeyeri Michael, "Computer Aided Design of Coupling" *International Journal of engineering* vol. 5, August 2011
- [2] Ruchik D. Trivedi, Dhaval B.Shah, Kaushik M. Patel " 3D-Parametric for product variant using case study on inner ring spherical roller bearing", *International conference on engineering* , Nirama university, 2012
- [3] Baraa M.H. Al-Baghdadi, Wissam K. Hamdan, Hussam L.A. Al- Mamori, "An integrated approach to design and Analyze unprotected type flange coupling", *University of Technology*, 2005.
- [4] Siraj MohammadAli Sheikh, "Analysis of Universal Coupling Under different torque condition"*International Journal of engineering and science & Advance Technology* vol.2, March 2012
- [5] S.B. Jaiswal, M.D. Pasarkar, "Failure Analysis of Flange Coupling in Industry", *International Journal of Emerging Technology and Advanced Engineering*, vol. 2, May 2012.
- [6] Shrikant.V.Peshatwar, L.P Raut, "Design and development of Fixture for eccentric shaft" *International Journal of Engineering Research and Applications*, vol. 3, February 2013.
- [7] "Machine Design Data book" Tata McGraw-Hill Publishing Company, 2004, pp 585-593
- [8] C.S.Sharma, Kamlesh Purohit, "Design of Machine Element" PHI Learning pvt. Ltd. , 2002, pp 508-560
- [9] Richard G. Budayans and J. Keith Nisbett "shigly's Mechanical Engineering Design", 9th edition, Tata McGraw-Hill Publishing Company, 2011, pp 359-400
- [10] R.S.Khurmi and J.K.Gupta "A text book of Machine Design", *Euraisa Publication House*, 2005, pp 470-508
- [11] Jon R. Mancuso "Coupling and Joints", 2nd Edition, *Marcel Dekker Inc.*, 2012, pp 75-80, pp 247-258.
- [12] CMTI, "Machine Tool Design Handbook". *Tata McGraw-Hill Publishing Company*, 2008 pp 103-110.
- [13] PSG College of Technology, "Design Data" , *Kalaikathir achchaga*, 2005, pp-7.120
- [14] Lou Tylee, "Learn Visual Basic 6.0", 1998.